



### SPECIFICATION:

**LENGTH:** 63<sup>3</sup>/<sub>8</sub>"

**WIDTH:** 37<sup>1</sup>/<sub>2</sub>"

**HEIGHT:** 78<sup>1</sup>/<sub>2</sub>"

**STYLE:** Barrier free shower

**SHIPPING WEIGHT:** 255 LBS\*

**COLOR:** White

### OPTIONAL:

- Padded Seat
- L- Grab Bar (JOR6336BFSLB)
- U-Grab Bar (JOR6336BFSUB)
- Straight Grab Bar
- Vertical Angle Grab Bar
- Added Backing (JOR6336BFSAB)
- 1<sup>1</sup>/<sub>4</sub>" Threshold (JOR6336BFSNR)

## JORDAN SERIES

This shower stall finished surface shall be of a premium sanitary-grade polyester gelcoat with a minimal thickness of 15 dry mills and a finished cured Barcol hardness of 80-90. The unit shall have outer dimensions of 63<sup>3</sup>/<sub>8</sub>" x 37<sup>1</sup>/<sub>2</sub>" x 78<sup>1</sup>/<sub>2</sub>". Sides & back of unit shall be constructed of molded reinforced fiberglass with 15% minimum fiberglass content plus an inner core of 7/16" wafer board extending the height and width of the walls and is laminated with another layer of reinforced fiber glass for superior overall rigidity. The base of the unit shall be attached to form an integral part with an inner & outer coating of reinforced fiberglass with polyester resin. Unit shall be recessed in sub-floor with overall depth determined by thickness of finished floor material. Threshold of the unit shall be 1/2" above the finished floor. Warranted against defects in material or workmanship for period of 3 years from date of installation. The addition of grab bars or fixtures not properly installed by purchaser shall void this warranty.

### ADA COMPLIANT

Code Compliance is based on our interpretation of applicable codes. We cannot assume responsibility for code compliance on your specific project. Please check specifications and other information with the appropriate authorities before ordering. ADA Accessibility Guidelines ADAAG -Sections 1-4 4.21.7 curbs. If provided, curbs in shower stalls 36" x 36" shall be no higher than 1/2". Shower stalls that are 30" x 60" minimum, shall not have curbs.

#### Venco Products Ltd. (Delta)

7584 Vantage Place, Delta, BC V4G 1A5  
Tel: (604) 940-4960  
sales@venco.ca

#### Venco Products Ltd. (Nanaimo)

1960 Cedar Road, Nanaimo, BC V9X 1L7  
Tel: (250) 722-2522  
islandsales@venco.ca



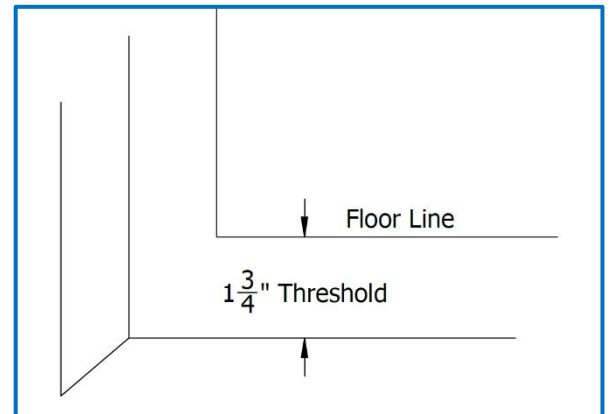
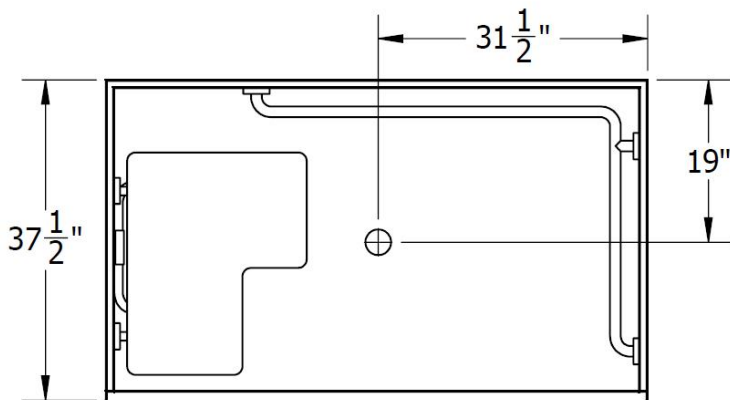
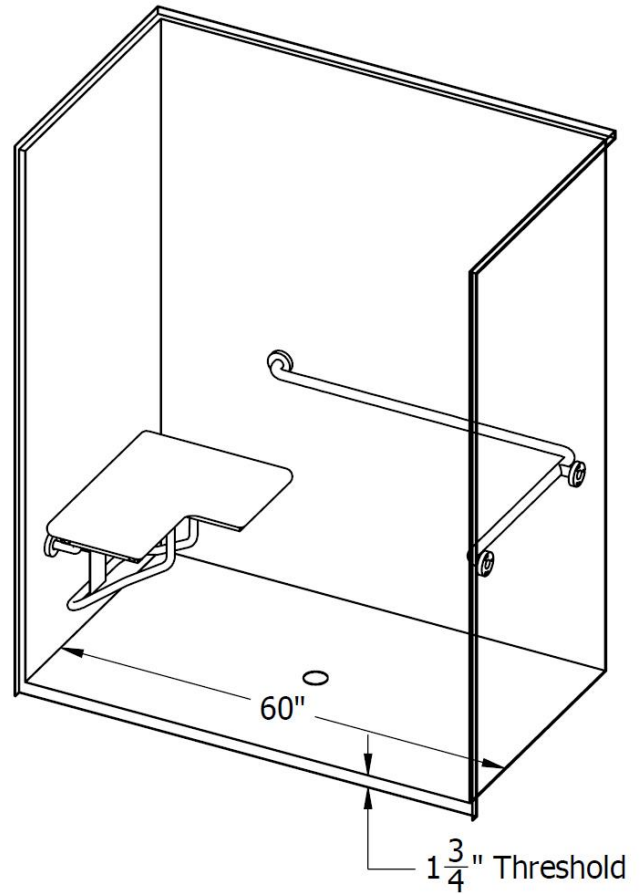
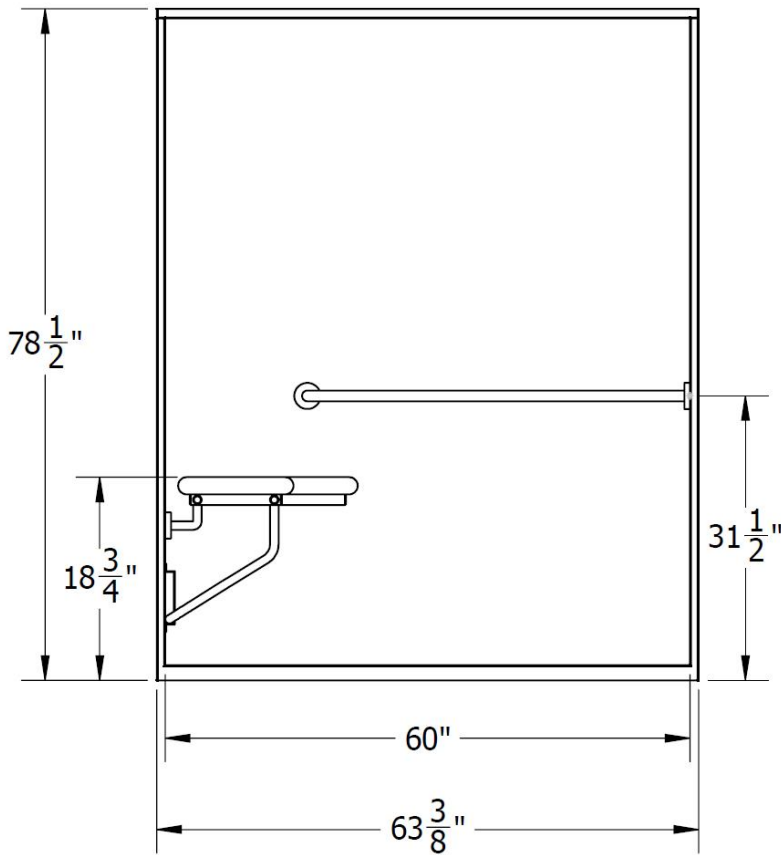

### Note:

- All the measurements are in inches & have tolerance of  $\pm \frac{1}{4}$ ".
- All the Grab Bars & Padded Seat are installed with added backing.
- All dimensions include Dry Wall Flanges

# SPECIAL NEEDS SHOWERS | JORDAN

MODEL | JOR6336BFSLB (L-Grab Bar) | JOR6336BFSUB (U-Grab Bar)

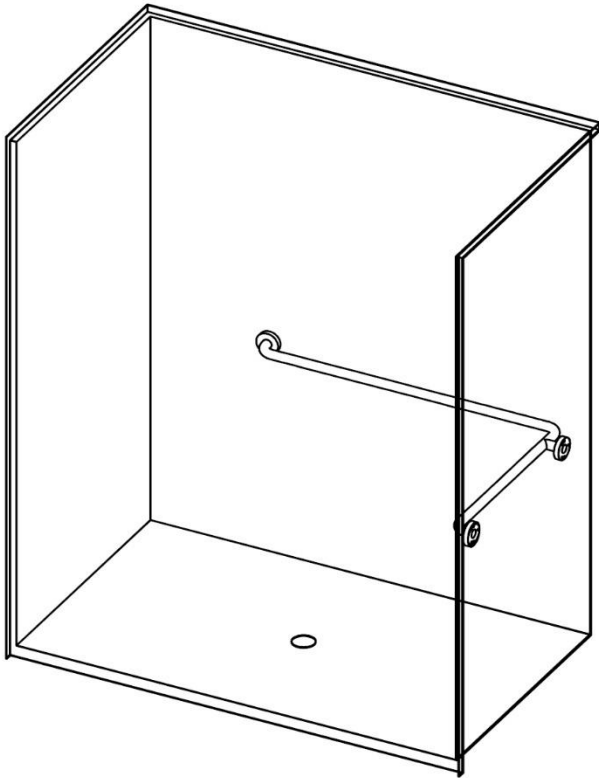

**JOR6336BFSLB**

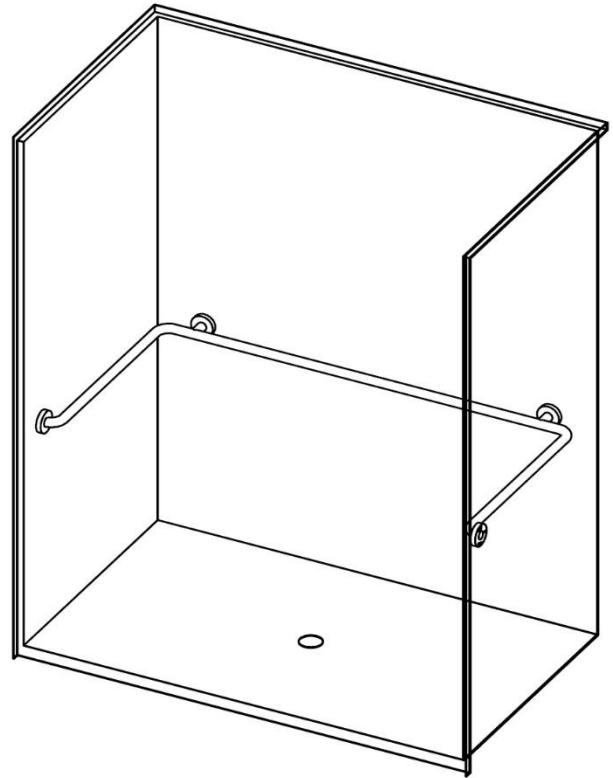

**JOR6336BFSUB**

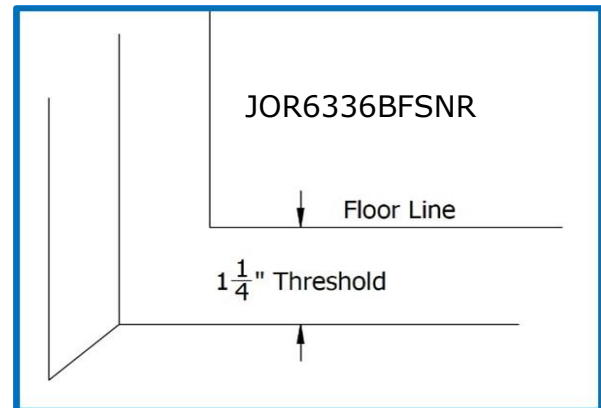
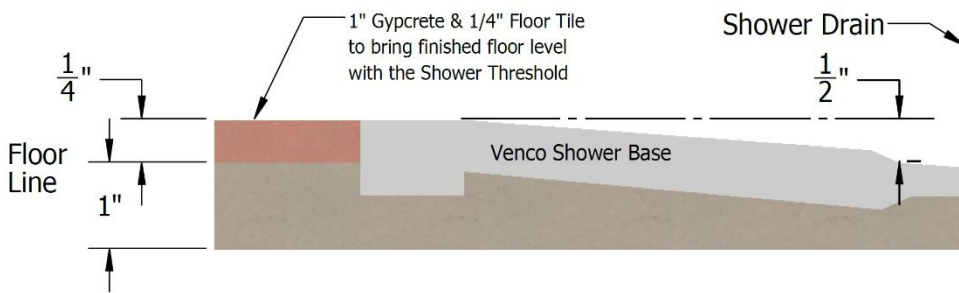

## Note:

- All the measurements are in inches & have tolerance of  $\pm 1/4"$ .
- All the Grab Bars & Padded Seat are installed with added backing.
- All dimensions include Dry Wall Flanges

## Attachments:

### Stainless steel Grab-Bar:

The unit shall have one stainless steel "L" shaped wrap around grab bar mounted horizontally on the valve side and extending to the back wall. Stainless steel "L" shaped grab bar will be 1<sup>1</sup>/<sub>4</sub>"O.D. 18-gauge type #304 stainless steel, mounted with stainless steel nuts, bolts and washers. Fastened from the back side of the unit and sealed and caulked to meet ASTM F-466 specifications. All stainless-steel grab bars meet Federal Specification WW-P541/8b, Amendment 1, 16 April 1990; ANSI 117.1 and all A.D.A. code requirements. These bars, when properly installed, meet 900lb downward pull requirement for Federal Specification work, F.H.A., V.A., HOSPITAL CODES AND PRIVATE CONSTRUCTION.

### Fold-up Seat:

This unit shall include a removable White padded seat that meet Fed.Spec.WW-P-541/8b,Amendment 1, April,1990 and ANSI 117.1. When properly installed this seat is designed and manufactured to exceed all applicable federal load specifications and comply with all A.D.A. requirements. The seat frame is Type 304(18-8) stainless steel tubing, 1<sup>1</sup>/<sub>4</sub>"x 18ga. square frame with 1" x 18ga. round cross members. The wall flanges are (2) type 304 (18-8) stainless steel flanges,10 ga x 3" diameter, heliarc welded to 1" round x 18 ga. 90-degree leg support and to 1<sup>1</sup>/<sub>4</sub>" round x 12 ga. frame hinge couplings. Three mounting holes in each flange. The support leg in "U" shaped yoke of type 304 (18-8) stainless steel tubing,1" round x 18 ga. heliarc welded to 1<sup>1</sup>/<sub>4</sub>" round 12 ga. frame hinge couplings. The guide bracket is type 304 (18-8) stainless steel 10ga. x 3" wide constant friction wall mounted guide bracket with positive stop for raised position. This seat has 250lbs sitting capacity when installed properly.

This unit is designed to comply with: ANSI A117.1-1992, ADA The Americans with Disabilities Act-1991 C.S.A APPROVED. Warranty is to the original purchaser only, that this unit is free from manufacturing defects in material or workmanship for a period of 3 years from date of intallation.The Addition of grab bars or fixtures not properly installed by purchaser shall void this warranty.

## IMPORTANT

While we strive to provide accurate measurements for our customers, sometimes mistakes happen. Our goal is to help things run smoothly from shipment to installation, so if you notice any errors in our spec sheets, please let us know.

Our products are handmade & hand finished so you can expect a tolerance of  $\pm \frac{1}{4}$ " on all measurements. We strongly recommend waiting until your ordered product is on-site before attempting any rough-in carpentry or plumbing.

If you want to verify any of our measurements, please feel free to call or email us.

Keeping with our policy of continuing product improvement, Venco Products Ltd. reserves the right to change product specifications without notice.

---

### Venco Products Ltd. (Delta)

7584 Vantage Place, Delta, BC V4G 1A5  
Tel: (604) 940-4960  
sales@venco.ca

### Venco Products Ltd. (Nanaimo)

1960 Cedar Road, Nanaimo, BC V9X 1L7  
Tel: (250) 722-2522  
islandsales@venco.ca



**VENCO.CA**