

MODEL | UTO6032SK L/R | ACRYLIC



### SPECIFICATIONS

**LENGTH:** 59<sup>3/4</sup>"

**WIDTH:** 31<sup>3/4</sup>"

**HEIGHT:** 20<sup>1/2</sup>"

**IMMERSION DEPTH** 12"

**SHIPPING WEIGHT** 65 LBS\*

**WATER CAPACITY** 46 US GAL\*

\* Approximately

### Flange Series

MODEL | UTO6032FL L/R

- Available with flange (2")

### Wood Apron Series

MODEL | UTO6032FLWA L/R

- Factory installed wood apron for tiling
- Setback for tiles should be mentioned at the time of order

### Available Upgrades

- Water jetting system
- Air jetting system
- Combination air water
- Chromatherapy
- Acrylic grab bars
- Premium colours: Bone and Biscuit

## UTOPIA SERIES

### Product Features

- 100% acrylic with fiberglass & wood reinforcement
- Textured bottom
- Available in left or right hand drain
- Leveling feet included
- Double integral tiling flange
- Backrest angle: 110°
- End drain hole: 2"
- 5 Year limited manufacturer's warranty included

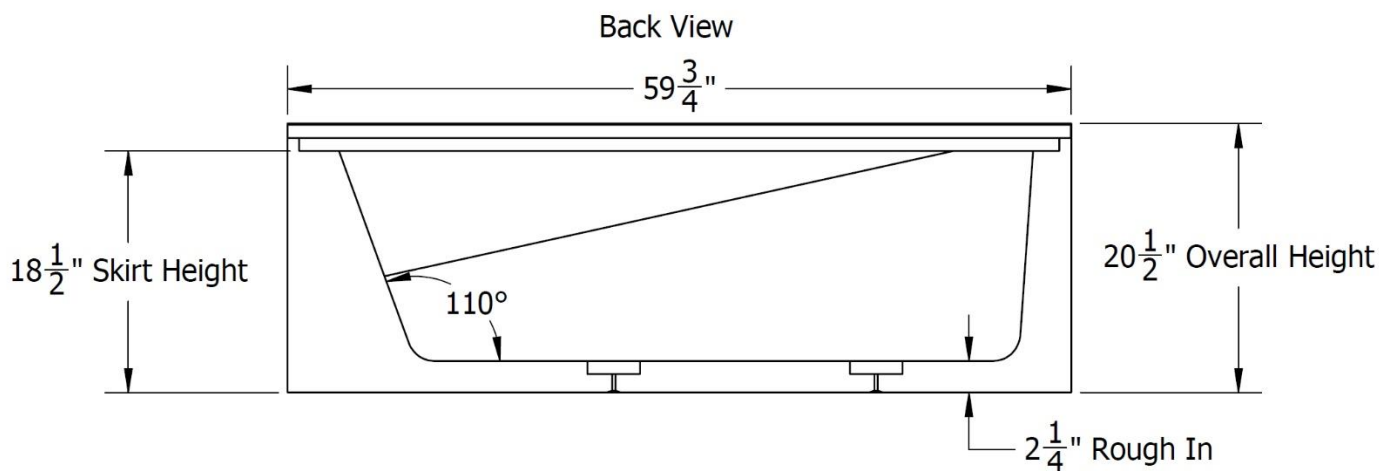
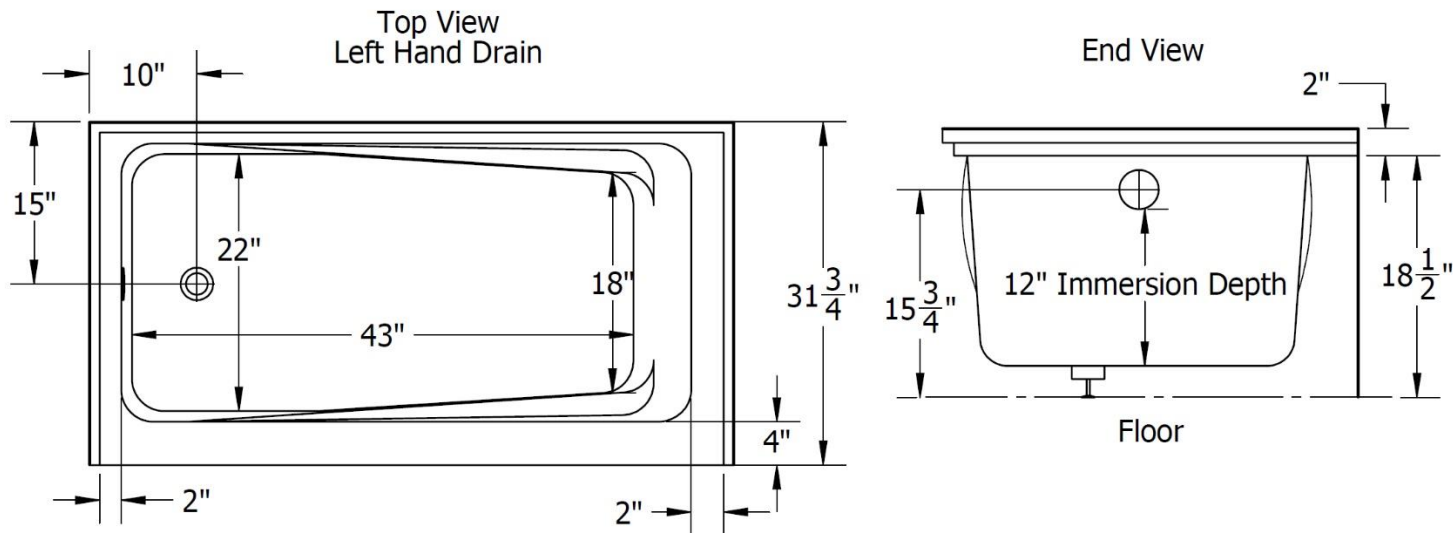

**Note: ALL THE MEASUREMENTS ARE IN INCHES & HAVE TOLERANCE OF ± 1/4"**

### IMPORTANT

While we strive to provide accurate measurements for our customers, sometimes mistakes happen.

Our goal is to help things run smoothly from shipment to installation, so if you notice any errors in our spec sheets, please let us know.

Our products are handmade & hand finished so you can expect a tolerance of ± 1/4" on all measurements. We strongly recommend waiting until your ordered product is on-site before attempting any rough-in carpentry or plumbing.

If you want to verify any of our measurements, please feel free to call or email us.

Keeping with our policy of continuing product improvement, Venco Products Ltd. reserves the right to change product specifications without notice.



**VENCO.CA**

### Venco Products Ltd. (Delta)

7584 Vantage Place, Delta, BC V4G 1A5

Tel: (604) 940-4960

sales@venco.ca

### Venco Products Ltd. (Nanaimo)

1960 Cedar Road, Nanaimo, BC V9X 1W1

Tel: (250) 722-2522

islandsales@venco.ca