



Specifications	
Length	60"
Width	60"
Height	22"

IMMERSION DEPTH	15^{1/2}"
SHIPPING WEIGHT	80 LBS*
WATER CAPACITY	62 US GAL*

* Approximately

Design Features

- Textured bottom
- Corner style with seat

Available Upgrades

- Water jetting system
- Air jetting system
- Combination air water
- Chromatherapy
- Acrylic grab bars
- Premium colors:
Biscuit

ANTIGUA SERIES

Product Specifications

- 100% acrylic with fiberglass & wood reinforcement
- Leveling feet included.
- Backrest angle: 117°
- End drain hole: 2"
- 5 Year limited manufacturer's warranty included



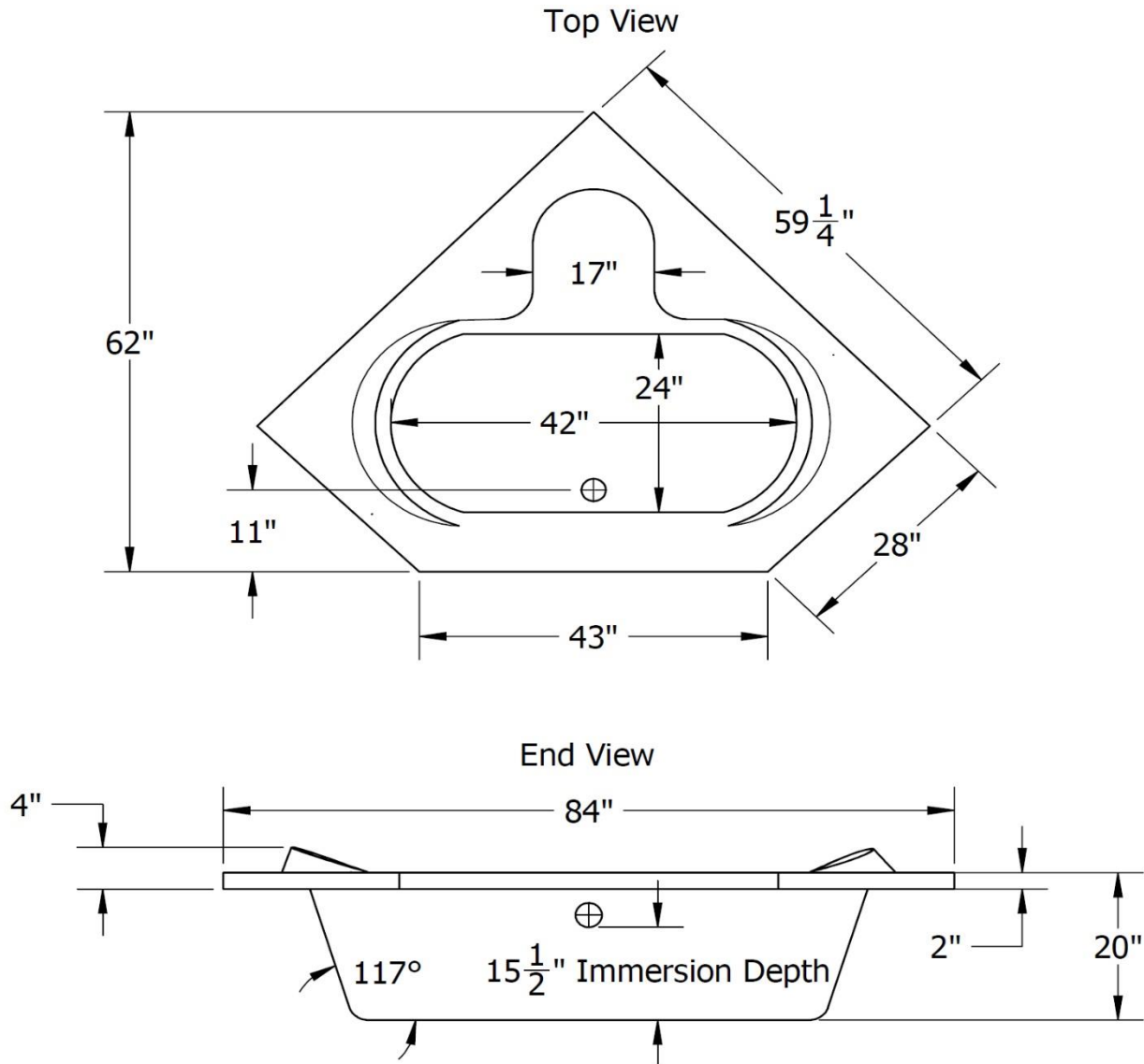

All Dimensions are in inches & have tolerance of ± 1/4"

IMPORTANT

While we strive to provide accurate measurements for our customers, sometimes mistakes happen. Our goal is to help things run smoothly from shipment to installation, so if you notice any errors in our spec sheets, please let us know.

Our products are handmade & hand finished so you can expect a tolerance of ± 1/4" on all measurements. We strongly recommend waiting until your ordered product is on-site before attempting any rough-in carpentry or plumbing.

If you want to verify any of our measurements, please feel free to call or email us.

Keeping with our policy of continuing product improvement, Venco Products Ltd. reserves the right to change product specifications without notice.



Venco Products Ltd. (Delta)

7584 Vantage Place, Delta, BC V4G 1A5
 Tel: (604) 940-4960 | Fax: (604) 940-9733
 sales@venco.ca

Venco Products Ltd. (Nanaimo)

1960 Cedar Road, Nanaimo, BC V9X 1W1
 Tel: (250) 722-2522 | Fax: (250) 722-2404
 islandsales@venco.ca